



ITALIANPRO

ELEVATOR GEARED-GEARLESS
MACHINES & COMPONENTS

PROI320 Series





ITALIANPRO

ELEVATOR GEARED-GEARLESS MACHINES & COMPONENTS

Features

Load:320~630kg

Roping:2:1

Voltage:380V、220V

IP Code:IP41

Brake Vol:DC110V

Working System:S5-40%

Speed:0.4~1.75m/s

Static Load:3000kg

INS.Class:F

Poles:16

Brake Current:1.75A

Overall Dimensions

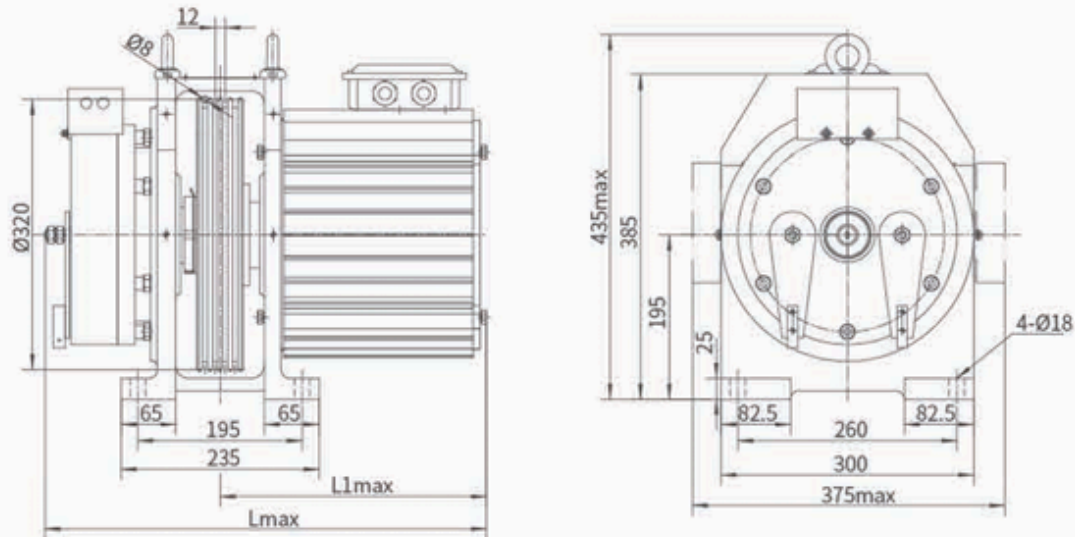

Size Specification Table

(Spec.)	L (mm)	L1 (mm)
PROS320/400/450	510	300
PROS630	565	355



ITALIANPRO

ELEVATOR GEARED-GEARLESS MACHINES & COMPONENTS

PROI320 Series Gearless Traction Machine Specification (Roping 2:1)

Type	Load (kg)	Speed (m/s)	Power (kW)	Current(A) 380V/220V	Speed (rpm)	Frequency (Hz)	Torque (N.m)	Sheave (mm)	Rope n×a-b	Net Weight (kg)
PROS320	320	0.4	0.9	3.9/6.8	48	6.4	175	320	3×Ø8-12	150
	320	0.5	1.1	3.9/6.8	60	8	175	320	3×Ø8-12	150
	320	0.63	1.3	4.6/8	75	10	175	320	3×Ø8-12	150
	320	1.0	2.2	5.4/9.3	119	15.9	175	320	3×Ø8-12	150
PROS400	400	0.4	1.1	4.9/8.5	48	6.4	215	320	3×Ø8-12	150
	400	0.5	1.3	4.9/8.5	60	8	215	320	3×Ø8-12	150
	400	0.63	1.7	5.8/10	75	10	215	320	3×Ø8-12	150
	400	1.0	2.7	6.7/11.6	119	15.9	215	320	3×Ø8-12	150
PROS450	450	0.4	1.3	5.6/9.7	48	6.4	245	320	4×Ø8-12	150
	450	0.5	1.6	5.6/9.7	60	8	245	320	4×Ø8-12	150
	450	0.63	1.9	6.5/11.3	75	10	245	320	4×Ø8-12	150
	450	1.0	3.2	7.6/13.2	119	15.9	245	320	4×Ø8-12	150
PROS630	630	0.4	1.7	7.5/13	48	6.4	340	320	5×Ø8-12	170
	630	0.5	2.1	7.5/13	60	8	340	320	5×Ø8-12	170
	630	0.63	2.7	8.4/14.5	75	10	340	320	5×Ø8-12	170
	630	1.0	4.2	9.8/17	119	15.9	340	320	5×Ø8-12	170
	630	1.5	6.4	16.2/28	179	23.9	340	320	5×Ø8-12	170
	630	1.6	6.8	16.2/28	191	25.5	340	320	5×Ø8-12	170
	630	1.75	7.4	16.2/28	209	27.9	340	320	5×Ø8-12	170