



# ITALIANPRO

ELEVATOR GEARED-GEARLESS  
MACHINES & COMPONENTS

## PROI268V / PROI268H Series





# ITALIANPRO

## ELEVATOR GEARED-GEARLESS MACHINES & COMPONENTS

### Features

Static Load:5000kg

Lifting Height:12m/15m

Rated Load:P+Q=1150kg

Brake Vol:DC110V

Brake Current:1.5A

Roping:1:1

Working System:S5-25%

Reduction Ratio:1/8

Roller Diameter:270mm

Rope:2-8/10

Weight:215kg

Gear Lubrication:H4.5L/V5.5L

### Positive Drive Machine Installation Method Diagram

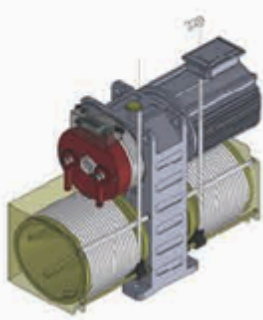

D-type 268V: Bottom mounted vertical upward rope outlet

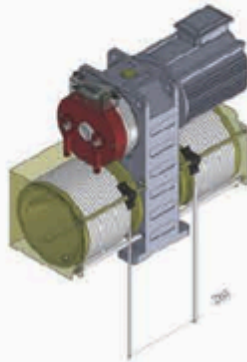

E-type 268V: Upward mounted vertical downward rope outlet

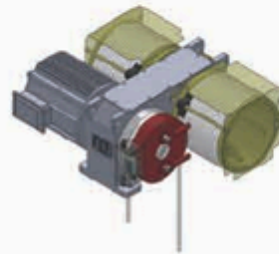

A-type 268H: Upward mounted horizontal downward rope outlet

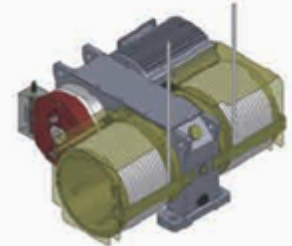

C-type 268H: Bottom mounted horizontal upward rope outlet

### PROI268V/PROI268H Series Positive Drive Traction Machine Specification

Type	Load (kg)	Speed (m/s)	Power (kW)	Current(A) 380V/220V	Speed (RPM)	Frequency (Hz)	Output Torque (N.m)	Poles
PROI268V /PROI268H	700	0.3	2.1	8.1/12.5	170	22.6	945	16
	800	0.3	2.4	9.2/13.5	170	22.6	1080	16
	900	0.3	2.7	10.4/15	170	22.6	1215	16
	1000	0.3	3	11.5/16.5	170	22.6	1350	16
	700	0.4	2.8	8.1/12.5	226	30.2	945	16
	800	0.4	3.2	9.2/13.5	226	30.2	1080	16
	900	0.4	3.6	10.4/15	226	30.2	1215	16
	1000	0.4	4	11.5/16.5	226	30.2	1350	16
	1150	0.4	4.6	13.3/—	226	30.2	1555	16



# ITALIANPRO

## ELEVATOR GEARED-GEARLESS MACHINES & COMPONENTS

### Installation dimensional drawing

#### PROI268V vertical mounting dimension

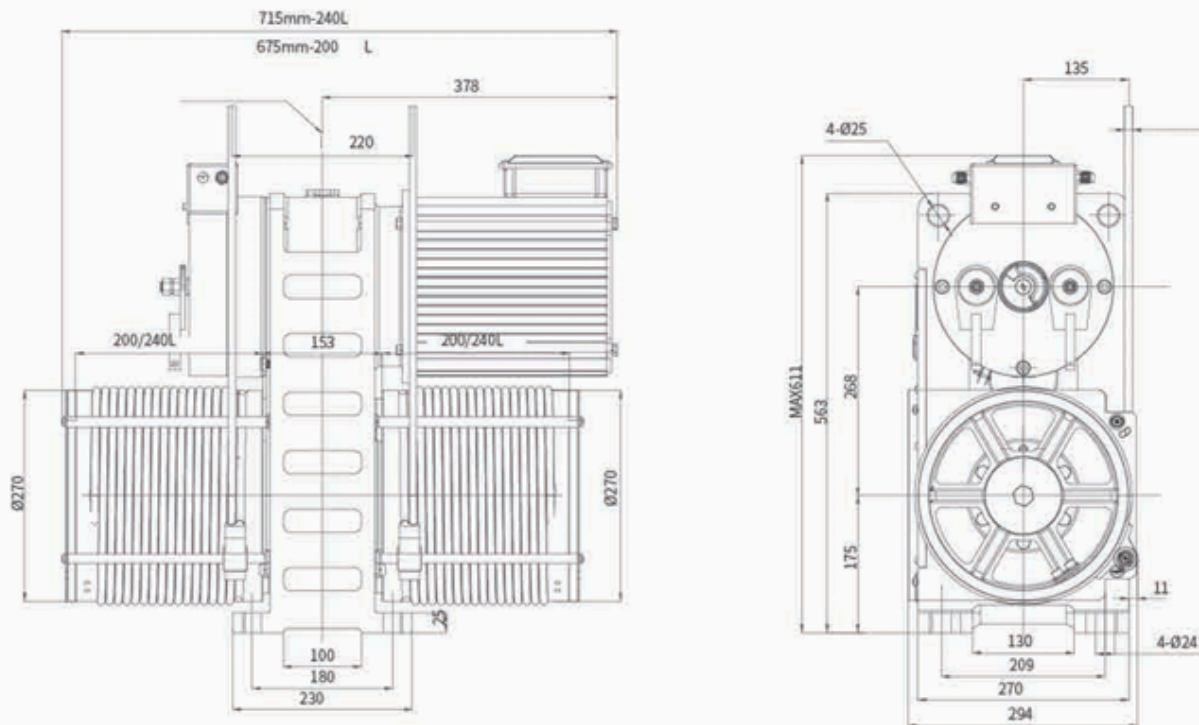

#### PROI268H horizontal mounting dimension

