



# ITALIANPRO

ELEVATOR GEARED-GEARLESS  
MACHINES & COMPONENTS

## PRO1128 Series





# ITALIANPRO

## ELEVATOR GEARED-GEARLESS MACHINES & COMPONENTS

### Features

- Static Load:4500kg
- Lifting Height:4.5/8/12m
- Rated Load:P+Q=700Kg
- Brake Vol:DC110V
- Brake Current:1.1A
- Roping:1:1
- Working System:S5-25%
- Reduction Ratio: 1/10
- Roller Diameter:Φ240mm
- Rope:2-Φ8
- Weight):110kg
- 320#
- Gear Lubrication: 3.5L

### Positive Drive Machine Installation Method Diagram

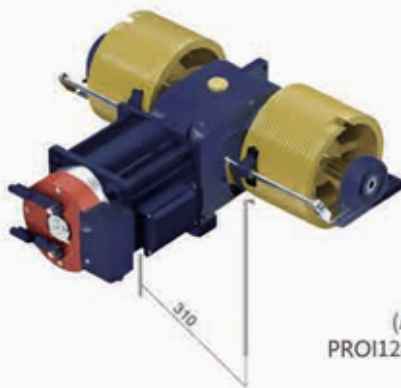

(A type):  
PRO1128-8~12m

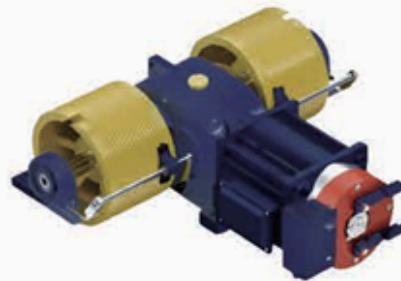

(B type):  
PRO1128-4.5m

### PRO1128 Series Positive Drive Machine Machine Specification

Type	Load (kg)	Speed (m/s)	Power (kW)	Current(A) 380V/220V	Speed (rpm)	Frequency (Hz)	Torque (N.m)	Poles
PRO1128	500	0.15	0.75	3.4/5.8	120	16	600	16
	600	0.15	0.9	4.1/7.0	120	16	720	16
	700	0.15	1.1	4.7/8.2	120	16	840	16
	500	0.3	1.5	3.6/6.2	240	32	600	16
	600	0.3	1.8	4.4/7.5	240	32	720	16
	700	0.3	2.1	5.0/8.7	240	32	840	16



# ITALIANPRO

## ELEVATOR GEARED-GEARLESS MACHINES & COMPONENTS

Installation dimensional drawing

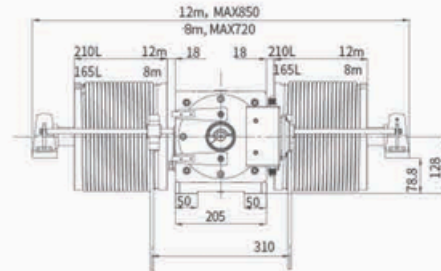
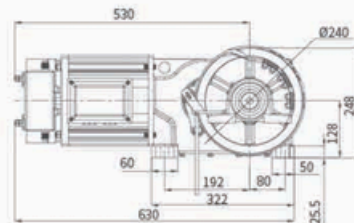

PRO1128-8-12m mounting dimension

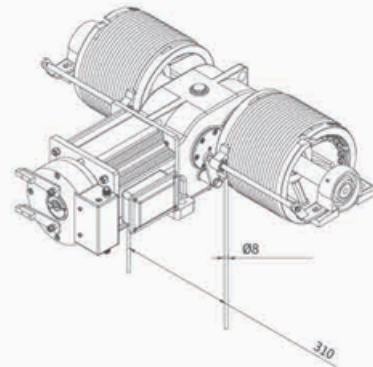
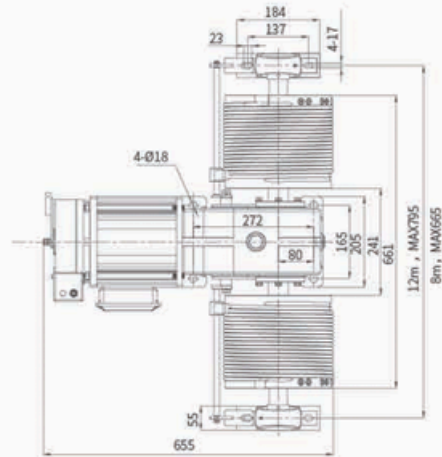

PRO1128-4.5m mounting dimension

