



# ITALIANPRO

ELEVATOR GEARED-GEARLESS  
MACHINES & COMPONENTS

## PRO1100X - FG Series





# ITALIANPRO

## ELEVATOR GEARED-GEARLESS MACHINES & COMPONENTS

### Features

Load:320~630kg

Roping:2:1

Voltage:380V、 220V

IP Code:IP41

Brake Vol:DC110V

Working System:S5-25%

Speed:0.3~1.0m/s

Static Load:3000kg

INS.Class:F

Poles:16

Brake Current:1.1A

### Overall Dimensions

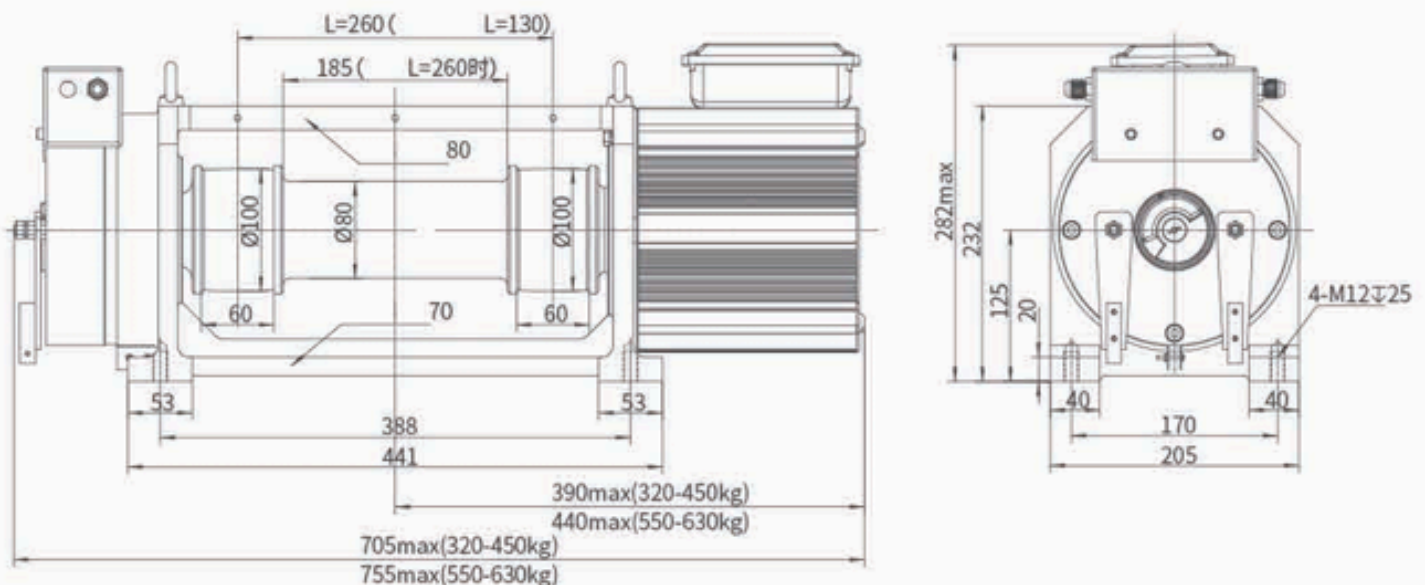



# ITALIANPRO

## ELEVATOR GEARED-GEARLESS MACHINES & COMPONENTS

### PROI100X-FG Series Gearless Traction Machine Specification (Roping 2:1)

Type	Load (kg)	Speed (m/s)	Power (kW)	Current(A) 380V/220V	Speed (rpm)	Frequency (Hz)	Torque (N.m)	Sheave (mm)	Rope nxa-b	Net Weight (kg)
PROD320	320	0.3	0.7	4.4/4.4	115	15.3	55	100	2x30-260	80
	320	0.4	0.9	4.4/4.4	153	20.4	55	100	2x30-260	80
	320	0.5	1.1	3/5.2	191	25.5	55	100	2x30-260	80
	320	0.63	1.3	3/5.2	241	32.1	55	100	2x30-260	80
	320	1.0	2.2	5.3/9.2	382	50.9	55	100	2x30-260	80
PROD400	400	0.3	0.9	5.5/5.5	115	15.3	70	100	2x30-260	80
	400	0.4	1.1	5.5/5.5	153	20.4	70	100	2x30-260	80
	400	0.5	1.3	3.8/6.5	191	25.5	70	100	2x30-260	80
	400	0.63	1.7	3.8/6.5	241	32.1	70	100	2x30-260	80
	400	1.0	2.7	6.7/11.6	382	50.9	70	100	2x30-260	80
PROD450	450	0.4	1.3	6.2/6.2	153	20.4	80	100	2x30-260	80
	450	0.5	1.6	4.3/7.4	191	25.5	80	100	2x30-260	80
	450	0.63	1.9	4.3/7.4	241	32.1	80	100	2x30-260	80
	450	1.0	3.2	7.5/13	382	50.9	80	100	2x30-260	80
PROD630	630	0.4	1.7	5.3/9.2	153	20.4	110	100	2x30-260	90
	630	0.5	2.2	6.6/11.5	191	25.5	110	100	2x30-260	90
	630	0.63	2.7	6.6/11.5	241	32.1	110	100	2x30-260	90
	630	1.0	4.4	9/15.6	382	50.9	110	100	2x30-260	90