



ITALIANPRO

ELEVATOR GEARED-GEARLESS
MACHINES & COMPONENTS

PROI100E-FG Series





ITALIANPRO

ELEVATOR GEARED-GEARLESS MACHINES & COMPONENTS

Features

Load:450~800kg

Speed:0.5~1.0m/s

Roping:2:1

Static Load:3000kg

Voltage:380V、220V

INS.Class:F

IP Code:IP41

Poles:16

Brake Vol:DC110V

Brake Current:1.5A

Working System:S5-40%

Overall Dimensions

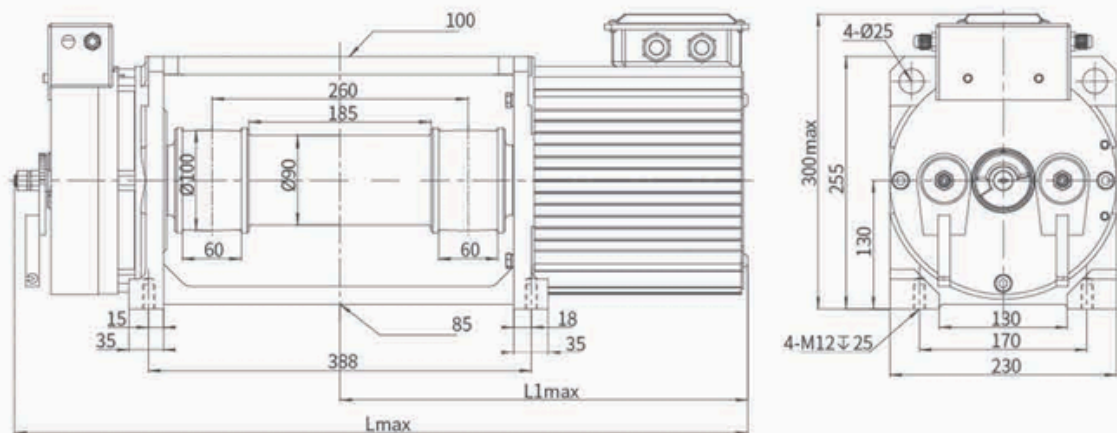

Size Specification Table

(Spec.)	L (mm)	L1 (mm)	(Belt Breaking Strength)
PROD450	745	415	42kN
PROD630	745	415	42kN
PROD800	785	455	52kN



ITALIANPRO

ELEVATOR GEARED-GEARLESS MACHINES & COMPONENTS

PROI100E-FG Series Gearless Traction Machine Specification (Roping 2:1)

Type	Load (kg)	Speed (m/s)	Power (KW)	Current(A) 380V/220V	Speed (rpm)	Frequency (Hz)	Torque (N.m)	Sheave (mm)	Rope nxa-b	Net Weight (kg)
PROD450	450	0.5	1.6	4/6.9	191	25.5	80	100	2x30-260	110
	450	0.63	1.9	5/8.7	241	32.1	80	100	2x30-260	110
	450	1.0	3.2	6.5/11.2	382	50.9	80	100	2x30-260	110
PROD630	630	0.5	2.2	5.5/9.5	191	25.5	110	100	2x30-260	110
	630	0.63	2.7	6.3/10.9	241	32.1	110	100	2x30-260	110
	630	1.0	4.4	9/15.6	382	50.9	110	100	2x30-260	110
PROD800	800	0.5	2.7	6.8/11.8	191	25.5	135	100	2x30-260	130
	800	0.63	3.4	8/13.8	241	32.1	135	100	2x30-260	130
	800	1.0	5.4	11/19	382	50.9	135	100	2x30-260	130